

Detailed Options Working Session Notes

Following are RTA staff notes from the four **technical working sessions** held on August 7 and 8 at the RTA offices at 175 W. Jackson Blvd., Suite 1550 to discuss each of the following topics:

1. I-290 Corridor
2. Transportation Management and Operations (TM&O)
3. J Tail and West Termini
4. Circulation/Distribution Systems

The purpose of the sessions was to convene agency and local experts with working and field knowledge to exchange professional insight, information and ideas. The goal of the sessions was to clarify particularly challenging or undefined aspects of the current working versions of the detailed Options (dated August 3), as identified by the RTA staff/consultant team.

Topic: I-290 Corridor
Date: Monday, August 7 at 1:30 PM
Participants:

John Baczek	IDOT-District 1, DOH
Tunde Balvanyos	Pace
Michael Bolton	Pace
Rob Cole	Village of Oak Park
Peter Fahrenwald	CTA
Richard Hazlett	CDOT
Chuck Kadlec	IDOT-DIPT
Michael Koperniak	Village Oak Park
David Kralik	Metra
Tam Kutzmark	DuPage Mayors and Managers Conference
Beth McCluskey	North Central Council of Mayors
Andrew Parker	Pace
Jose Rodriguez	CMAP
David Tomzik	Pace
Bill Lenski	RTA
Michelle Ryan	RTA
Tony Catalina	American Consulting Engineers
Tim Crobons	Connetics Transportation Group
John O'Holleran	American Consulting Engineers

In this session, participants discussed possible improvements in the I-290 corridor (approx. Lake Street to Cermak Road, Hillside Interchange to downtown Chicago), constraints and ROW availability.

Potential improvements included in one or more of the working options are listed below:

- Bus Rapid Transit (BRT) on Cermak and I-290,
- Reversible and 2 lane High Occupancy Vehicle (HOV) facility on I-290,
- MidCity BRT and Diesel Multiple Unit (DMU),
- Inner Circ DMU,
- Transportation Management & Operations (TM&O) Arterial Improvements,
- New arterial connector (bus) service,
- CTA Blue Line extension to 1st Ave and to Oak Brook,
- CTA Pink Line extension to Harlem,
- Operational and capital improvements on Metra UP-W and BNSF lines, and CTA Green, Blue and Pink lines.

Physical characteristics and constraints to consider in options development:

- The pinch point is between 1st Ave. and Harlem, but there would be right-of-way (r-o-w) impacts no matter what.
- CTA indicated the old Chicago, Aurora & Elgin (CA&E) railroad r-o-w could be used for an extension of the Blue Line to 1st Ave. and the old Com Ed facility could provide space for a needed yard.
- CA&E r-o-w could be used for an extension to 1st Ave and the Illinois Prairie Path (IPP) bikeway r-o-w further west to the Indiana Harbor Belt (IHB) railroad.
- Bringing the Blue Line further west than Hillside would be very difficult to do – and no one had any ideas/suggestions.
- Pace has had some discussion on shuttles using the CA&E.
- Questions were raised but there was no information available about IHB improvement plans in the CREATE freight plan. Chuck Kadlec will follow up.

- While there are several pinch points along the current Blue Line, for the most part there is room (r-o-w) for a third rail along its current extent.
- A continuous third set of tracks is not absolutely necessary for express service – this potentially could be accomplished with strategic availability of a third set of rail/sidings.
- It may not be physically feasible for additional lanes on I-290 to co-exist with a third, continuous set of tracks along the existing limits of the CTA Blue Line/Forest Park branch.
- Use of the roads paralleling I-290 was also suggested for potential new transit options.
- In an option with MidCity, HOV should extend a little further east than currently planned; should go to Cicero Avenue/MidCity. Or, the gap between the Austin HOV terminus and the MidCity could be a bus ramp.
- If MidCity is a BRT (or busway) the vehicles could continue west on the HOV all the way through to the proposed J Line BRT, and provide numerous combinations of direct service.
- Discussed possibility of bus only lanes rather than HOV lanes; Pace felt strongly that bus only lanes would not be desirable due to driver frustration if the lane is temporarily empty (no bus in sight).
- Shoulder riding on I-290 will be explored, which is a kind of bus-only lane.
- Compatibility/incompatibility of vehicles (e.g., trucks, buses, cars, etc.) in a managed use lane should be carefully considered.
- It was broadly felt that if nothing is done to add capacity to I-290, extensive improvement would be needed to North Avenue, St. Charles Road, Madison Street, Roosevelt, and Cermak.

Summary of follow-up items:

- Chuck Kadlec to investigate IHB upgrade plan and provide list of CREATE Improvements impacting the Cook DuPage Corridor;
- Michelle to follow up with Beth on Maywood's plan for a bicycle corridor using the CAE connecting to the Forest Park Blue Line Station.

Outcomes:

- Additional lanes on the Eisenhower for use by buses only should not be pursued in any option.
- HOV lanes and a Blue Line extension west of Des Plaines Avenue are not physically compatible within the existing I-290 r-o-w and should not be combined in the I-290 r-o-w within any option.
- CTA Blue Line extension to 1st Avenue was agreed to be beneficial from a number of standpoints and may be incorporated into several options.
- Options should strive for seamless transfers through common transfer/interface points and schedule coordination.

Topic: Transportation Management & Operations (TM&O) Arterial Corridors

Date: Monday, August 7 at 3:00 PM

Participants:

John Baczek	IDOT-District 1, DOH
Tunde Balvanyos	Pace
Michael Bolton	Pace
Rob Cole	Village of Oak Park
Peter Fahrenwald	CTA
Kim Grabow	City of Naperville
Richard Hazlett	CDOT
Chuck Kadlec	IDOT-DIPT
Michael Koperniak	Village Oak Park
Tam Kutzmark	DuPage Mayors and Managers Conference
Andrew Parker	Pace
Jose Rodriguez	CMAP
David Tomzik	Pace
Bill Lenski	RTA
Michelle Ryan	RTA
Tony Catalina	American Consulting Engineers
Tim Crobons	Connetics Transportation Group
John O'Holleran	American Consulting Engineers

Participants discussed strategies and improvements to take into account in TM&O corridor recommendations, what strategies are already employed, challenges/barriers in specific corridor areas (including on-street parking, pedestrian movements, technologies), and additional strategies for corridors that include bus services.

Roadways currently identified as TM&O Corridors (Smart Corridors) are as follows:

East-West Arterial Corridors

- Irving Park Road (IL 19)
- North Avenue (IL 64)
- Roosevelt Road (IL 38)
- Cermak Road/22nd Street/Butterfield (IL 56)
- Ogden Avenue (US 34)
- 55th Street
- 75th Street
- Warrenville Road/Ferry Road
- Diehl Road

North-South Arterial Corridors

- Cicero Avenue (IL 50)
- Harlem Avenue (IL 43)
- Cumberland Avenue/1st Avenue (IL 171)
- Des Plaines River Road
- Mannheim Road/LaGrange Road (US 12/20/45)
- Kingery Highway (IL 83)
- Naperville Road/Gary Avenue
- IL 59

The following potential TM&O strategies and physical improvements are currently under consideration in the development of detailed options:

Traffic and roadway operations efficiency, arterial enhancement

- a. *Expressway interchanges and access*
- b. *Access control, side streets*
- c. *On-street parking*
- d. *One-way pairs*
- e. *Intersection treatments and design*
- f. *Bus bays*
- g. *Truck and commercial traffic*

Bus operations efficiency and reliability

- h. *Queue jumping*
- i. *Signal priority*
- j. *Bus stop placement*
- k. *Exclusive use lanes in high congestion areas*

Intelligent transportation systems design, operation

- l. *Traffic signal systems design and operation*
- m. *Real time travel and transit information*
- n. *Incident management*

Physical characteristics and constraints to consider in options development:

- There is a local trend toward **landscaped medians** that may run counter to some strategies and benefits of TM&O corridors. For example, North Avenue in Oak Park and Roosevelt Road through Oak Park and Berwyn (between Harlem Ave. to Austin Blvd.) are/have been improved with landscaped medians.
- Naperville's experience has been that landscaped medians do not reduce traffic volumes, but do reduce speeds – usually reducing speeds TO the speed limit.
- Where TM&O is recommended for Corridors for which landscaped medians are planned, reduction in travel times may not be a suitable/best evaluation measure.
- On the plus side, landscaped medians improve aesthetics and also provide a safety zone for pedestrians. On the downside, it was noted that pedestrian improvements can hurt flow, as it gives extra green time to side streets.
- **Elimination of driveway cuts** was agreed by all as an important and valuable TM&O objective. Strategies to accomplish this include shared driveways, service roads/lanes, and reducing number of curb cuts to the same business etc.
- Naperville has a policy for curb cut elimination.
- Elmwood Park is also reducing curb cuts and undertaking street scaping, and Downers Grove is undertaking a similar effort along Ogden Avenue.
- It was noted that businesses tend not to like shared parking facilities, particularly with potential competitors.
- Naperville more likely to go pursue **one-way pairs** than elimination of on street parking.
- Correction to materials: IL 59 should be listed as a Smart Corridor (currently IL 59 is identified on map, but omitted from text).
- **Signalized left turn bays** would be useful, particularly on Ogden Avenue
- There seems to be general consensus that some physical improvements to intersections and additional signaling and **improved/regular signal timing optimization** and maintenance would also be important for TM&O corridors.
- Naperville undertakes regular maintenance of signal optimization, and will soon be undertaking a SCAT-type study of IL 59 (Note: refers to IDOT's Signal Coordination and Timing program)
- Both Pace and CTA are now going **to far side (of intersection) bus shelters/stops**. Ogden Avenue at Austin and Harlem were offered for examples.

- The distance of the shelter/stop from the intersection is subject to physical conditions specific to each location.
- **Bus bays** are useful, where feasible. But they do need to be designed to be easy to get into and out of.
- Also consider instances where a circulator/distributor/other service could pull up parallel to bus bay from a parking lot, for example for easy transfer.
- **Pedestrian access** and shelter area very important. Others indicated that sidewalk facilities most important along and to destination areas.
- Rail-highway **grade separations** are also important, such as 25th Avenue at Grand and 1st Ave at Lake Street; land issues were noted.
- Pace indicated that **queue jumping** as a strategy was of lower priority than the far side bus stop strategy and that of highest priority was improving flow on arterials in general (for all traffic), to benefit bus travel well.
- **Incident management** on expressways and arterials is an important strategy, and the existing Chicago Traffic Management Center (TMC) and the proposed DuPage County area TMC should be considered for this purpose, as well as expansion of the IDOT Minutemen service area.
- I-95 Corridor (Montgomery Co., MD) was suggested as an example of a TMO Corridor.

Summary of follow-up items:

- Note: after the meeting Oak Park shared with the RTA some examples of incident management/preparedness programs in their community that are not suited for group discussion (for security reasons). Nevertheless, the strategies - in a more general sense - will be further considered by the RTA staff/consultant team in the development of detailed options.

Outcomes:

- Reduction/elimination of curb cuts, signal optimization, protected left turn lanes, and far side bus stops with bus bays surfaced as some of the most potentially effective and desirable types of TM&O improvements.
- Need to identify a set of standard/minimum TM&O improvements for arterials with and also arterial without transit.
- May need to identify where landscaped medians are planned/likely to occur and an appropriate set of TM&O strategies for such an environment, or a recommendation for specific design treatment to all or a portion of the landscaped median itself.
- We'll also need to expect - and perhaps educate others on - the trade off that, to some extent, landscaped medians and improved pedestrian crosswalks at major arterial intersections, may offset some benefits otherwise achieved from the application of TM&O strategies for the sole purpose of cars, buses and trucks.
- Planning Standards Working Group and Technical Committee will be apprised of the discussion on the importance of aesthetics to communities - perhaps even more than improved mobility. The issue may warrant planning standards consideration.
- We will need to identify which recommended TM&O strategies currently exist/already are deployed in each TM&O Corridors before evaluating costs and potential benefits, and certainly before finalizing recommendations.
- I-95 Corridor description resources identified: <http://www.i95coalition.org> and <http://144.202.240.28/pman/projectmanagement/Upfiles/reports/full83.PDF>.

Topic: J Route Tail (West Segment and Western Terminus)

Date: Tuesday, August 8 at 9:00 AM

Participants:

Tunde Balvanyos	Pace
Michael Bolton	Pace
Bob Dean	City of Naperville
Bob Huffman	Pace
David Kralik	Metra
Tam Kutzmark	DuPage Mayors and Managers Conference
John Loper	DuPage County
Andrew Parker	Pace
David Snell	Pace
David Tomzik	Pace
Bill Lenski	RTA
Michelle Ryan	RTA
Tony Catalina	American Consulting Engineers
Tim Crobons	Connetics Transportation Group
John O'Holleran	American Consulting Engineers

This session addressed potential BRT/express/local service variations, alignments and western termini for the DuPage J route.

The following J Route alignments (west leg) and termini are under preliminary consideration in the development of detailed options:

- I-88 to Naperville Road, then southwest through Naperville to 95th Street/STAR Line (as depicted in the DuPage Area Transit Plan),
- I-88 to Winfield Road, then north to Cantera
- I-88 to IL 59, then south on IL 59
- IL 59 at I-88
- I-88 to STAR Line
- I-88 to Naperville Road, then west on Warrenville Road/Ferry Road or Diehl Road to Cantera
- IL 59 at 95th Street,

Physical and operational characteristics and constraints to consider in developing J Route west segment and termini

- DMMC's understanding of J Route implementation as outlined in the DuPage Area Transit Plan (DATP) is that it would begin with a minimal capital segment and that the J Route would be gradually phased in over time and to the investment level/intensity warranted by demand.
- I-88 or IL 83 was assumed to be the pieces that potentially warrant exclusive right of way requiring major capital investment.
- Naperville considers the planned 95th Street STAR Line station an important terminus, as they have major land use plans for that location. But the route through Naperville from I-88 to the 95th Station as proposed in the DATP is not preferred. It was suggested that IL 59 would appear to be more suitable.
- IL 59 would likely require expansion and TM&O treatments to serve as a BRT corridor. The underpass with the BNSF currently restricts expansion. Naperville noted that there are plans to widen IL 59.

- Book Road was discussed as a potential alternative route to IL 59, but Naperville noted that it may be too residential and doesn't have the same potential for connecting key places like Fox Valley Mall, IL 59 BNSF Station, etc.
- To accommodate future growth, Aurora near I-88 may be a worthy endpoint for the tail.
- There could be multiple tails; however, it would not make sense to have both a tail through Naperville as represented in the DATP and a tail on IL 59
- The tails may not be BRT or require major capital investment.
- The tails could all go to a transfer point (for example, IL 59 at I-88 or Cantera on Winfield Road, or Naperville Road) to access a higher capacity BRT which would then connect to Oak Brook, O-Hare and Schaumburg.
- Alternatively, there could be multiple tails that operate as local services and then share use of an exclusive facility along I-88, Warrenville Road or Cermak Road.
- Pace noted that pedestrian bridges to stations in I-88 right of way would be needed and suggested researching examples in Ottawa and Minnesota.
- Pace also noted that arterial alignments would offer more development/redevelopment opportunities than would Interstate alignments.
- Pace noted that they need a "spine" to be identified, from which they can develop a network or family of services.
- Pace also relayed that they did not have a perspective on where the "spine" should be and would like for the consultants to propose this.
- ART is Arterial Rapid Transit.
- Pace diagrammed the following for working group members to explain several different types of services in terms of the vehicle used, the stop spacing, service type and the capital/funding requirements, and referenced this as a toolbox for others to use:

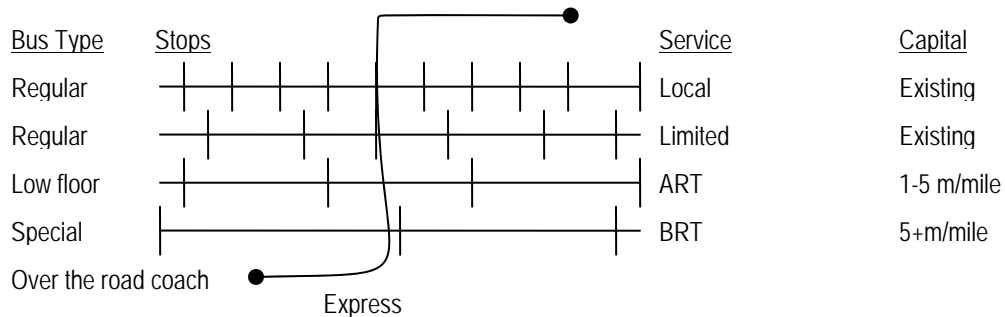

Summary of follow-up items:

- John Loper arranged a small group discussion on Aug. 17 to present some additional ideas for potential alignment and service type/level.
- Pace to e-mail PowerPoint slides to RTA that indicates the information/graphics they have on existing and potential routes by service level/type.
- We will follow up on suggested examples implemented in other cities.

Outcomes:

- We will explore multiple alternative and complementary tails;
- IL 59 will be assumed for the focus of connecting J Route service through Naperville.

Topic: Circulation/Distribution systems

Date: Tuesday, August 8 at 10:30 AM

Participants:

Tunde Balvanyos	Pace
Ed Barsotti	League of IL Bicyclists
Adolfo Benages	City of Oak Park
Ed Barsotti (phone)	League of IL Bicyclists
Rob Cole	Village of Oak Park
Bob Dean	City of Naperville
Bob Huffman	Pace
David Kralik	Metra
Tam Kutzmark	DuPage Mayors and Managers Conference
Aimee Lee	CTA
Randy Neufeld	Chicagoland Bicycle Federation/Healthy Streets Campaign
Andrew Parker	Pace
David Snell	Pace
David Tomzik	Pace
Bill Lenski	RTA
Michelle Ryan	RTA
Tony Catalina	American Consulting Engineers
Tim Crobons	Connetics Transportation Group
John O'Holleran	American Consulting Engineers

This session addressed modes for last mile distribution systems and related improvements to facilities, amenities.

Following are the purposes of circulation/distribution systems for consideration in Cook DuPage Corridor options development:

- collection,
- distribution, particularly to identified employment centers,
- local versions of express services,
- in conjunction with other transportation improvements.

Physical and operational characteristics and constraints to be considered for:

Bus/shuttle distribution systems

- Shelters are important and should provide a clean and secure environment, including trash receptacles and a means for emergency contact.
- Bicycle rack should be available at/near shelters.
- Bus stop standards should be considered.
- Information on the transportation system and specific services should be available on buses and at shelters, rather than advertising.
- Pedestrian safety at adjacent intersection is critical.
- Additional detailed study of market potential, route and schedules will likely be needed, like that underway for thirteen communities participating in the DuPage Circulator Study (a separate, related effort being lead by DMMC).

Bicycle distribution systems

- There are important physical barriers near Corridor employment centers (e.g., freeways)
- In this Corridor context, bicycle distribution systems should be focused on as a link of a commute trip, as opposed to the sole means of a trip.
- A reasonable maximum bike trip distance is typically considered 3 miles, but 2 miles might be better. The trip time may better establish "feasible" for most.
- On street bike lanes are typically preferred by cyclists, but the curb cuts/driveways and traffic volumes/speeds on suburban arterials pose a great hazard to bicycling.
- Bike paths connecting stops/stations with employment centers are critical, particularly in this environment.
- Storage facilities at key transfer points, including overnight facilities for reverse commuters, are important.
- Velo'V in Lyon, France is a model bike system (subscription) developed by JC DeCeaux that may have some potential application in the Corridor. Especially for employment centers with non-peak, split shift or part time jobs (e.g., industrial/manufacturing in Elmhurst/Addison.) if a peak-oriented transit distribution system is developed.
- Velo'V may also be practical to get peak workers from stations to workplaces dispersed within an overall employment center like Oak Brook.

Pedestrian distribution systems

- Pedestrian travel distance is considered 3/8 to 1/2 mile.
- Pedestrian facilities at key transfer points, to, and within employment centers are critical.

Automobile collection/distribution systems

- Illumination is important and proximity to a main thoroughfare.
- There needs to be an easy connection (very proximate) to transit system.
- Maintenance and operating cost of park and ride lots may be an issue.

Summary of follow-up items

- Visit www.completestreets.org
- Share information about Velo'V with Technical Committee and Citizen Advisory Committee for more input and gauge of interest

Outcomes:

- Will identify and/or recommend facilities/amenities to make bicycle a viable option for last mile link.
- Transit distribution systems will be viewed as the "necessary" link to trunk line systems; bicycle systems as an option.
- Pedestrian systems/improvements need to be addressed for 1/2 mile distances between station/stops and employment centers.
- On-going circulator service planning efforts will be noted in materials.